

# Reliability Assessment and Study the Effect of Substation Feeder Length on Failure Rate and Reliability Indices

**Mandefro Teshome, Fsaha Mabrahtu**

School of Electrical and Computing Engineering, Haramaya Institute of Technology, Haramaya University, Dire Dawa, Ethiopia

**Email address:**

Mandefroteshome7@gmail.com (M. Teshome), m24fsaha@gmail.com (F. Mabrahtu)

**To cite this article:**

Mandefro Teshome, Fsaha Mabrahtu. Reliability Assessment and Study the Effect of Substation Feeder Length on Failure Rate and Reliability Indices. *American Journal of Electrical Power and Energy Systems*. Vol. 9, No. 3, 2020, pp. 41-46.

doi: 10.11648/j.epes.20200903.11

**Received:** February 17, 2020; **Accepted:** March 26, 2020; **Published:** August 17, 2020

---

**Abstract:** Today, utilities are trying to maximize system reliability, improve efficiency, and reduce costs by using protection system, distributed generation system, by reconfiguring the feeder, by connecting the end of feeder to other substation and so on. However, when it tries to use some techniques (reconfiguring the feeder, connecting the end of the feeder to another substation); the techniques have positive and negative impact on reliability improvement. The substation which is taken in this paper has the System Average Interruption Frequency Index (SAIFI) and System Average Interruption Duration Index (SAIDI) is 521.46 interruptions per customer per year and 446.82 hours per customer per year respectively. The historical outage interruption data of the years of 2016-2018 has been used as a base year. The study has evaluated the new substation to improve the system reliability. The simulation results have been done with the help of Electrical Transient Analysis Program (ETAP 12.6) software. In this paper includes improvement of the system reliability of the feeder is supplied from two substations or new substation should be connected at the end of the feeder. Due to the new substation, the length of the feeder will vary, and the variation of the feeder has significant effect on power reliability. The value of SAIFI and SAIDI after the new substation connected is 169 and 96 respectively. Since the new substation has negative impact, the value of indices is not reduced more.

**Keywords:** Network Reconfiguration, Power Reliability, New Substation, Reliability Indices, ETAP Software

---

## 1. Introduction

Power system is designed to provide sufficient electrical power supply to the customers in its area with an acceptable level of the supply reliability [1, 2]. Today, utilities try to maximize system reliability, improve efficiency, and reduce costs by using protection system, distributed generation system, by reconfiguring the feeder, by connecting the end of the feeder to other substation [3].

Protection systems play a significant role in the improvement of the system reliability [4]. Distributed Generation is a new technique based on renewable energy resources which will possibly participate as a vital entity of electric Power System [5-7].

Feeder reconfiguration is the process of changing the topology of distribution network by altering the open or closed status of switches [8-13]. When utility used feeder reconfiguration and new substation the length of the feeder

has been improved.

The length of the feeder has a direct significant effect on the value of reliability indices, i.e. the variation in length of feeder (due using new substation, Feeder reconfiguration) leads to the change in failure rate there by causing a variation on the value of reliability indices. However, research works or review articles reported so far on power reliability improvement did not give a great emphasis to the effect of variation in feeder length on the value of reliability indices.

This is paper will solve the gap between due attention to the mentioned gap above by considering the variation in failure rate as a crucial factor.

## 2. Methodology

The methodology of this thesis goes starting from the problem identification and reading helpful literatures. The problem identification is the first step towards solving the

public problem. For this particular problem in power distribution reliability, the study goes through literature survey on effect of Substation Feeder Length on Failure Rate and Reliability Indices solution and comes up with ideas of mitigating the problems. Bisidimo Feeder of Harar substation III is selected as case study area where interruption and high length problems are extremely marked. Data collection and analysis is done for the case study. Data obtained is organized such that it's easier to utilize it for distribution reliability implication. Then, the study implement mobile substation which is located around Hiwot fana referral hospital. Finally, existing system (before Bisidimo feeder connected to mobile substation) and after Bisidimo feeder connected to mobile substation is simulated using help of

Electrical Transient Analysis Program (ETAP 12.6) software.

### 3. Reliability Indices

The reliability of the power supply is calculated by using the reliability indices. These indices of distribution system analysis include energy oriented indices and customer oriented indices [14].

#### A. Customer Oriented Indices

##### i. System average interruption frequency index, SAIFI

It is the average frequency of sustained interruptions per customers over a predefined area.

Total number of customer interruptions per year divided by the total number of customers served.

$$SAIFI = \frac{\text{Total Number of Customer Interrupted}}{\text{Total Number of Customer Served}} = \frac{\sum \lambda_i N_i}{\sum N_i} \quad (1)$$

Where,  $\lambda_i$  is the failure rate and  $N_i$  is the number of customers of load point i.

##### ii. Consumer average interruption frequency index, CAIFI

This index gives the average frequency of sustained interruptions for those customers experiencing sustained interruptions. It is the value of the total number of customer interruptions divided by total number of customers affected.

$$CAIFI = \frac{\text{Total Number of Customer Interruptions}}{\text{Total Number of Customers Affected}} \quad (2)$$

##### iii. System average interruption duration index (SAIDI)

It is commonly referred to as customer minutes of interruption or customer hours and provides information to the average time the customers are interrupted.

$$SAIDI = \frac{\text{Some of Customer Interruption Durations}}{\text{Total Number of Customers Served}} = \frac{\sum U_i N_i}{\sum N_i} \quad (3)$$

Where,  $U_i$  is the annual outage time and  $N_i$  is the number of customers of load point i.

##### iv. Customer average interruption duration index (CAIDI)

This index gives the average frequency of sustained interruptions for those customers experiencing sustained interruptions. It is the value of total number of customer interruptions divided by total number of customers affected.

$$CAIDI = \frac{\text{Sum of Customer Interruption Durations}}{\text{Total Number of Customer Interruptions}} = \frac{\sum U_i N_i}{\sum \lambda_i N_i} \quad (4)$$

Where,  $\lambda_i$  is the failure rate,  $U_i$  is the annual outage time and  $N_i$  is the number of customers of load point i.

##### v. Average service availability (unavailability) index, ASAI (ASUI)

This index represents the fraction of time (often in percentage) that a customer has power provided during one year or the defined reporting period.

$$ASAI = \frac{\text{Customer Hours of Available Service}}{\text{Customer Hours Demanded}} \quad (5)$$

$$ASAI = \frac{\sum N_i \times 8760 - \sum U_i N_i}{\sum N_i \times 8760}$$

$$ASUI = 1 - ASAI$$

$$ASAI = \frac{\sum N_i * 8760 - \sum U_i N_i}{\sum N_i * 8760}$$

$$ASUI = 1 - ASAI$$

Where 8760 is the number of hours in a calendar year.

#### B. Load and energy orientated indices

i. Energy Not Supplied Index (ENS): This index represents the total energy not supplied by the system.

$$ENS = \sum L_{a(i)} U_i \quad (6)$$

Where,  $L_{a(i)}$  is the average load connected to load point i.

ii. Average Energy Not Supplied Index (AENS): This index represents the average energy not supplied by the system.

$$AENS = \frac{\text{Total Energy not Supplied}}{\text{Total Number of Customers Served}} = \frac{\sum L_{a(i)} U_i}{\sum N_i} \tag{7}$$

iii. Average Load Interruption Frequency Index (ALIFI):

This factor is analogous to the System Average Interruption Frequency Index (SAIFI) and describes the interruptions on the basis of connected load (kVA) served during the year by the distribution system.

iv. Average Load Interruption Duration Index (ALIDI):

This factor is analogous to the System Average Interruption Duration Index (SAIDI) and describes the number of hours on average that each kVA of connected load was without service [15, 16].

Harar town is one of the Ethiopian city which is located in Eastern side, and Harar Substation -III is found in this town

and it has eight feeders. These eight feeders are named by the local names of the area they are serving. These are: Kombolcha, Bisidimo, Aweday, Hamaressa Oil, Harar Water, Industry Zone, Fedis and Bedasa feeders.

In this paper, a special emphasis is given only to Bisidimo feeder of the city. This is because as per the data obtained from Harar substation -III, the mentioned city feeder has more frequency and duration interruptions than the other feeders in the existing substation. The feeder Average Interruption Frequency Index (SAIFI) and System Average Interruption Duration Index (SAIDI) are 521.46 interruptions per customer per year and 446.82 hours per customer per year, respectively.

**Table 1.** Percentage of average duration and frequency interruptions of different fault.

Feeders	Operational		TSC		PSC		TEF		PEF	
	%Fre	%Dur	%Fre	%Dur	%Fre	%Dur	%Fre	%Dur	%Fre	%Dur
Kombolcha	24.9	21.7	24.0	0.663	13.3	37.4	23.87	0.495	13.8	39.7
Bisidimo	23.6	24.8	24.2	0.816	12.3	31.5	22.68	0.836	17.1	374
Aweday	25.7	29.1	22.6	0.67	8.95	34.3	31.0	0.71	11.7	35.2
Hameraesa oil	15.7	14.0	15.3	0.52	15.2	39.9	43.6	0.815	10.0	44.73
Fedis	13.6	9.08	24.4	0.215	13.5	34.5	33.5	0.291	15.0	53.93
Bedasa	15.7	11.8	20.5	0.263	16.8	42.7	24.2	0.216	22.6	45.07
Average	20.6	15.6	22.7	0.413	13.3	38.2	26.82	0.411	16.44	45.41

**Table 2.** Calculated reliability indices the average of three years at Harar Substation -III.

Feeders	SAIFI Int/Cust/Yr	SAIDI Hr/cust/Yr	CAIDI Hr/int	ASAI %	ASUI %	EENS (MWh)	AENS (MWh)
Kombolcha	391	394.45	1.0005	0.955	0.4503	740.63	0.729
Bisidimo	521.33	446.2127	0.856	0.9645	0.0355	3,947.8	0.481
Aweday	327.67	289.11	0.997	0.967	0.033	990.97	0.3304
Hameraesa	76.33	115.70	115.70	0.9868	0.0132	758.21	0.1616
Fedis	289.67	870.36	2.947	0.905265	0.0947	572.61	1.3073
Bedasa	501	1089.65	2.334	0.8756	0.1244	1026.1	2.0341
Average	351.167	505.03	1.618	0.9423	0.0576	1339.4	0.8406

### 4. Result Analysis and Discussion

In this paper Electrical Transient Analysis Program (ETAP 12.6.0 version) software has been used to design, simulation and reliability assessment analysis tool. The values of failure

rates and mean time to repair for each component of static loads are necessary. To estimate the failure rate of the line per kilometer, the total number of outages should be divided by the feeder length (kilometers) as indicated in equation (8). The average mean time to repair (MTTR) each failure is computed using equation (9).

$$\lambda_A = \frac{\text{Total number of Interruptions}}{(\text{Total Feeder Length})(\text{Number of years})} \text{ (Int./km. year)} \tag{8}$$

$$MTTR = \frac{\text{Total Repair Time}}{\text{Total number of Interruption}} \text{ (Hr./Int)} \tag{9}$$

The length of Bisidimo feeder for this paper is 19.6km and the data is collected for three years. By using equation (8) and equation (9), the basic reliability parameters used in ETAP software for reliability analysis are calculated as follows:

$$\lambda_A = 521.33 / 58.8 = 8.866 \left( \frac{\text{Int}}{\text{km. year}} \right)$$

$$MTTR = 446.5667 / 521.33 = 0.8566 \text{ (Hr./Int)}$$

$$\lambda_A = \frac{521.33}{58.8} 8.866 \left( \frac{Int}{km \cdot year} \right)$$

$$MTTR = \frac{446.5667}{521.33} = 0.8566 (Hr. / Int)$$

To estimate the failure rate of a component, ETAP 12.6.0 uses a combination of active ( $\lambda_A$ ) and passive ( $\lambda_P$ ) failure rates together. The active failure rate is the number of failures per year per unit length. The passive failure rate is associated with the component failure mode that does not cause the operation of protection breakers and therefore does not have an impact on the remaining healthy components. Repairing or replacing the failed component will restore service [ETAP Software Library]. As there is no means of

isolating faulty areas in the system,  $\lambda_P$  is assumed as zero in the model.

In order to modeling the existing city distribution line and to analyze the current distribution reliability status, the following values have been considered as an input to ETAP 12.6 software. Such as: city line data, Cable length, number of customers, the connected load, number of transformers with their rating, active failure rate, duration of interruption in hours, frequency of interruption.

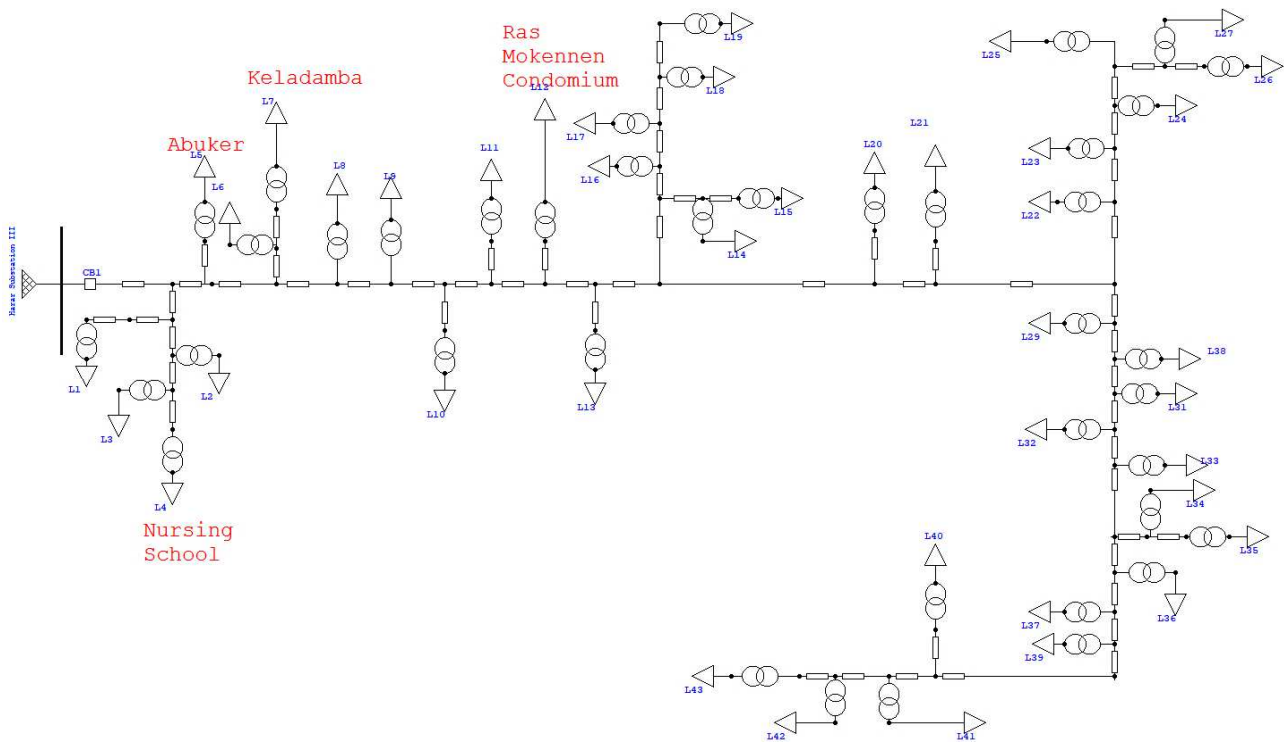

Figure 1. Harar city feeder line with existing SAIFI and SAIDI values.

Table 3. Simulation result of reliability indices for existing system (Before Bisidimo feeder connected to mobile substation).

Indices	Value
SAIFI	521.4559 f/customer.yr
SAIDI	445.815 hr/customer.yr
CAIDI	0.855 hr/customer interruption
ASAI	0.9491 pu
ASUI	0.05089 pu
EENS	4897.065MW hr/yr

Where; SAIFI is System Average Interruption Frequency Index, SAIDI is System Average Interruption Duration Index, CAIDI is Customer Average Interruption Duration Index, ASAI is Average Service Availability Index, ASUI is Average Service Unavailability Index, and EENS is Expected Energy Not Supplied.

Table 3 shows that the designed system has given the similar reliability indices output values as found from the

average of three years interruption data of Harar city. The two basic reliability indices, system average interruption frequency index and system average interruption duration index are 521.46 and 445.82 respectively. In this model the result of simulation is the same as to existing value.

Using New Substation on the Distribution Line

A new Harar mobile substation is located around Hiwot fana referral hospital (3.4 km far from the end of the feeder). It has been taped an electric power from Harar substation -III through 132 KV prior to the stepping down process. That is, a 132 kV transmission line is first stretched down to the new Harar mobile substation and then stepped down to 15 kV with 50 MVA transformers. Then, it will supply an electric power to Harar city and nearby areas. Harar mobile substation consists of four outgoing feeders with a radial network topology. The main primary feeder of the substation is branched into various primary laterals, which in turn

separated into several sub laterals. The total peak load of Harar mobile substation is estimated about 22 MW.

Hence, one Bisidimo feeder can be connected by tie switch without causing any problem on the new substation.

In this section the end of the feeder is connected to the new substation, so that the length of the feeder is increased from 19.6km to 23km. The increment of the feeder has both negative and positive on reliability indices. The positive impact is when the feeder supplied from two sides the reliability indices will be reduced, but when new substation or feeder reconfigured the length of the feeder will increase,

$$\lambda_A = \frac{521.33}{69} = 7.56 \left( \frac{\text{Int}}{\text{km. year}} \right) \text{ and } \text{MTTR} = 0.8566 \left( \frac{\text{Hr.}}{\text{Int}} \right)$$

the increment of the feeder has an effect on failure rate and this failure rate has negative effect on power reliability. Depending on this, the failure rate of the system or feeder is calculated as follows.

$$\lambda_A = 521.33/69 = 7.56 \text{ (Int./km.year)}$$

And

$$\text{MTTR} = 0.8566 \text{ (Hr./year)}$$

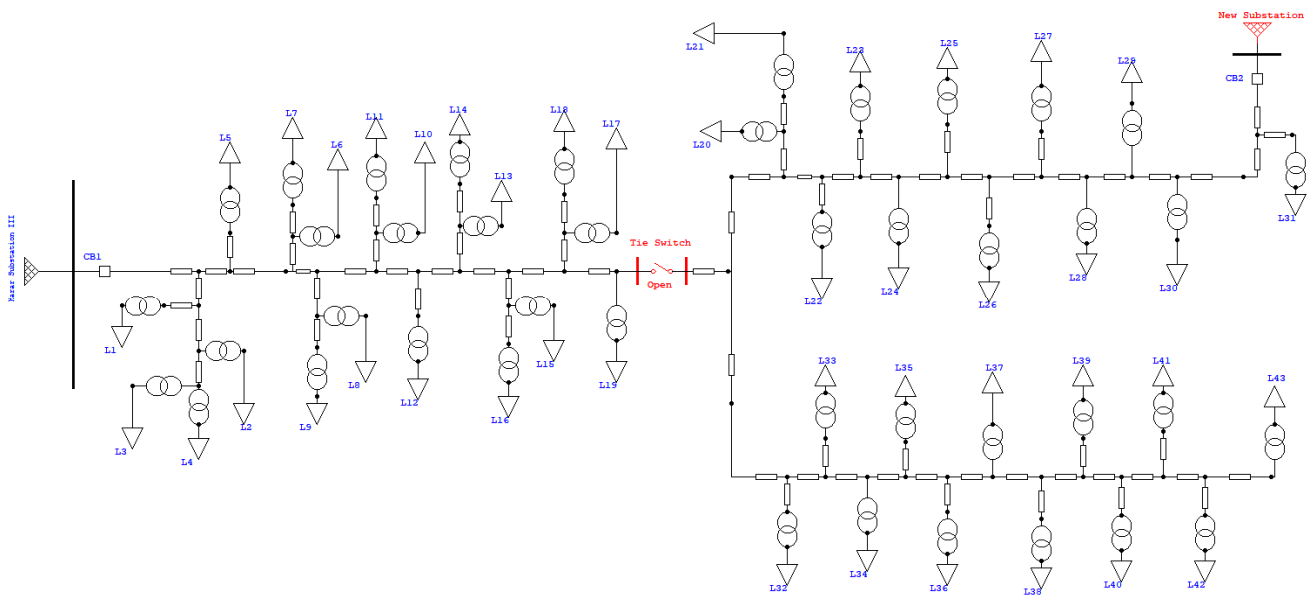

Figure 2. Single Line Diagram for Bisidimo Feeder of Harar Substation III after it Connected to New Substation.

In this method tie switch is placed at line (SL28), where SL is Segmented Line of the Feeder and mobile new substation is connected at the end of the feeder.

Table 4. Simulation result of reliability indices after Bisidimo feeder connected to mobile substation.

Indices	Value
SAIFI	169.02 f/customer.yr
SAIDI	96.0265 hr/customer.yr
CAIDI	0.568 hr/customer interruption
ASAI	0.9890 pu
ASUI	0.01096 pu
EENS	1424.708MW hr/yr

As shown in Table 4, the expected number of outages per year has been reduced from 521.4559 to 169.02 (67.56% system reliability has improved.), the annual outage duration has been reduced from 445.815 to 96.0265hours (78.47% reduction in outage duration) as compared with the existing system. In the section the reliability of Harar feeder is improved by 67.56%, 78.47% and 70.9% for SAIFI, SAIDI and EENS respectively. And also the interruption energy cost

can be calculated as,

$$\text{Interruption Cost} = 1424.71\text{MWh} \times 1000 \times 0.4409 \text{ ETB/kWh} = 628,154.64\text{ETB.}$$

Therefore the interruption energy cost has been decreased from 2,159,060.846 to 628,154.64ETB per year.

So in this work the reliability indices are not reduced well since there is a negative impact which is the length of feeder is increased.

## 5. Conclusions

The study focused on the reliability improved by connecting the new substation to the end of the feeder has both negative and positive effect. The average frequency interruption of existing Harar city feeder is 521.454 interruptions per customer per year (SAIFI). And also the average duration of the interruption is 446.5667 hours per customer per year (SAIDI). The average of unsupplied energy is 4,896.94 MWh per year. These results in a loss of around 2,159060.846 ETB per year from Ethiopia Electric Utility (EEU).

In this paper work, new substation have been proposed and analyzed for the implementation of reliability improvement in the study area. As the simulation result shows the power reliability indices reduced after new substation applied. Since this techniques has both negative and positive effect the indices does not reduced as required.

---

## References

- [1] S. Ahmad, S. Sardar, A. U. Asar, and B. Noor, "Impact of distributed generation on the reliability of local distribution system," in *IJACSA) International Journal of Advanced Computer Science and Applications* vol. 8, ed, 2017.
- [2] T. Gebreegziabher, "Study on smart grid system for improvement of power distribution system reliability case study: Addis Ababa District," Addis Ababa University, 2014.
- [3] Q. Matti Alias, N. Salman, and R. Yassen Abed, "Reliability Enhancement in Distribution Systems via Optimum Network Reconfiguration by using Gravitational Search Algorithm," *DIYALA JOURNAL OF ENGINEERING SCIENCES*, vol. 9, pp. 1-10, 2016.
- [4] S. SAMARGHANDI and M. SARHANGZADEH, "Reconfiguration and capacitor allocation in radial distribution systems with a new Independent loop identification method," *Leonardo Electronic Journal of Practices and Technologies*, pp. 23-44, 2017.
- [5] R. N. Azari, M. A. Chitsazan, and I. Niazazari, "Optimal recloser setting, considering reliability and power quality in distribution networks," 2017.
- [6] D. Zhu, "Power system reliability analysis with distributed generators," Virginia Tech, 2003.
- [7] S. Chatterjee, P. Nath, R. Biswas, and M. Das, "Advantage of DG for improving voltage profile over facts devices."
- [8] F. Carlsson, E. Demeke, P. Martinsson, and T. Tesemma, "Cost of Power Outages for Manufacturing Firms in Ethiopia: A Stated Preference Study," 2018.
- [9] C. H. N. de Resende Barbosa, M. H. S. Mendes, and J. A. de Vasconcelos, "Robust feeder reconfiguration in radial distribution networks," *International Journal of Electrical Power & Energy Systems*, vol. 54, pp. 619-630, 2014.
- [10] T. Abhiraj, B. M. Jos, and P. Aravindhbabu, "Dragonfly Optimization Based Reconfiguration for Voltage Stability Enhancement in Distribution Systems."
- [11] M. Sedighzadeh, M. Esmaili, and M. Mahmoodi, "Reconfiguration of distribution systems to improve reliability and reduce power losses using imperialist competitive algorithm," *Iranian Journal of Electrical and Electronic Engineering*, vol. 13, pp. 287-302, 2017.
- [12] D.-L. Duan, X.-D. Ling, X.-Y. Wu, and B. Zhong, "Reconfiguration of distribution network for loss reduction and reliability improvement based on an enhanced genetic algorithm," *International Journal of Electrical Power & Energy Systems*, vol. 64, pp. 88-95, 2015.
- [13] I. Dursun, F. Karaosmanoglu, and N. Umurkan, "Reconfiguration of actual distribution network with optimum power flow for loss reduction," *International Journal of Electronics and Electrical Engineering*, vol. 4, pp. 56-60, 2016.
- [14] A. Debru, "Study of Distributed Generation in Improving Power System Reliability (Case study: Addis Center Substation)," Addis Ababa University, 2016.
- [15] S. D. Gont and G. B. Worku, "Assessment of power reliability and improvement potential by using smart reclosers," *Zede Journal*, vol. 31, pp. 26-32, 2014.
- [16] A. Manasa, D. R. Kumar, and N. K. Kumari, "Power loss and Reliability optimization in Distribution System with Network Reconfiguration and Capacitor placement," *Power*, vol. 6, 2017.