Micro Network Protection by Synchronous Generators by the Use of Fault Current Limiter

J. Beiza, H. Mohebalizadeh, A. Kh. Hamidi

Department of Electrical Engineering, Shabestar Branch, Islamic Azad University, Shabestar, Iran

Email address:

Jamalbeiza@gmail.com (J. Beiza), Hmpeed@gmail.com (H. Mohebalizadeh), Abzhamidi@yahoo.com (A. Kh. Hamidi)

To cite this article:

J. Beiza, H. Mohebalizadeh, A. Kh. Hamidi. Micro Network Protection by Synchronous Generators by the Use of Fault Current Limiter. *American Journal of Electrical Power and Energy Systems*. Vol. 5, No. 2, 2016, pp. 17-21. doi: 10.11648/j.epes.20160502.12

Received: April 20, 2016; **Accepted:** May 3, 2016; **Published:** May 14, 2016

Abstract: Micro protection is one of the challenges ahead of micro network expansion. Micro network functions in two states of connection to network and island. The short connection level of micro network is different at two functional levels. Therefore, the protection system which needs to diagnose the faults at two states would function improperly. In the present article fault current limiter and oriented over-current relays optimal adjustment are implemented for micro network protection under the study. Additive particles optimal algorithm is used to adjust relays and fault current limiter impedance. The results show that by this method the micro networks can be secured at both two modes of functions.

Keywords: Micro Network, Protection Coordination, Over-Current Relays, Particles Optimal Algorithm

1. Introduction

Increasing problems related to air pollution the end of fossil fuels, depletion and congestion of transference system has caused the scattered products to be attended more than before. Micro-network is a new concept for a better utilizing of scattered product units and solving their technical problems. Micro-network is a complex of resources and loads which act under a single control unit from the network perspective. Micro-network has two types of functions: related to the network and island. In connected format the Micro-network invokes economic exchanges with the major network, anti-peak and offering complementary services. In times of turbulence in the main network the micro network can be separated from the main network and provide its loads in an island mode. The existence of scattered product units at distribution networks can lead to loss of coordination among these networks. Distribution networks mostly have radius structure where the fault current from the upper network is injected to the lower network by installing the scattered products the fault current level is increased and in addition to that we will observe the bidirectional fault currents in the distribution network. The current rate of short-circuit synchronous generators is considerable. The fault current of general electronic transformers is at 2-1 pre-unit level and

has less impact on short-circuit level [3-1].

Several methods have been implemented to establish protection coordination within distribution networks by the presence of scattered product units. These methods can be divided into two parts of optimizing and geometric parts. In optimizing methods, the objective function is the performance of all relays and under the optimizing conditions minimizing the function is pursued [9-4]. In the methods of the second group the attempt is to make use of the graphic theory to distinguish the major relays and sensitive ones and then the arrangement of other relays are done [11-10]. References [12-13] protection coordination is made for the configuration of different power systems by considering the inlet and outlet of the generators. References [14-15] have done the general analysis of the distribution systems protection impact on the scattered products. Reference [16] has implemented fault current in series format by scattered generation units and optimal arrangement of over current relays. In this research only the connected mode to the scattered products network; and the island mode has not been studied. To preserve the Micro-networks various methods are suggested. Two main protection challenges ahead of the Micro-network consist of changes of the short-circuit current

for two functional modes and the low cooperation of units with power electronic transformer in the fault current. Various methods have been suggested for the protection of the Micro-network so far and the researches in this respect are proceeding. At (2) digital relays with communication links on the basis of differential protection are implemented for the protection of the Micro-networks and voltage protection is introduced as the supportive protection. A similar method has been implemented in (3) on the basis of signal transference by the use of power lines and differential protection to keep the feeders have been presented. Micro-network protection system on the basis of central protection and communicational relations among the relays and protection unit has been presented. The central protection unit by determining the delay intervals and performance indexes and considering the mode of the Micro-network provides the apposite micro-network protection system (5-6-7-13). At (14) over current relays which are capable of identifying the performance mode for the protection of Micro-network protection system. Most of the suggested methods for the Micro-network protection system require communicational link between relays.

In the present article by the use of fault current limiter and optimal regulation of relays the Micro-network protection system will be dealt with. This article, is an attempt to solve, the extreme differences of short-circuit levels at two functional modes which makes use of additive particles algorithm for optimizing. The second part states the protection coordination issue and the third part describes the methodology and the simulated results are presented in part four.

2. Protection Coordination

The protection coordination of protective devices within a network can be achieved by the use of optimal optimizing and regulation. As mentioned earlier the function of the problem objective is as the following equation.

$$\text{MIN } \sum_{m=1}^2 \sum_{f=1}^{f_{\max}} (\sum_i (t_i + \sum_j t_{ij})) \quad (1)$$

Where i stands for main relay and j stand for protective relays t_i is the time of main relay performance and t_{ij} show the protective relays performance time equal to f error. m shows island or micro network performance mode with the network. The time of the protective relays performance need to be behind the main relay performance time to the amount of time coordination feedback. This condition is displayed at (2).

$$t_{ij}^f - t_i^f \leq CTI \quad (2)$$

In this article standard time reverse over current relays has been implemented. The features of the performance of these relays have been displayed at (3).

$$t = \frac{0.14 \times TDM}{\left(\frac{I_f}{I_p}\right)^{0.02-1}} \quad (3)$$

Where I_p is relay threshold current TDM is the relay regulation index and I_f is observed error current by relay

Relays current values are regulated at around 1.1-1.2 equal to relays currents. Relay regulation index changes in a disconnected way in practice but for the ease of action it has been used in an integral format. Since micro-networks function at two modes therefore, the load of relays will be different for both performance modes. In this study the maximum current load in both modes has been considered as the normal current load.

3. Fault Current Limiter and the Recommended Method

In the connected mode to the network because of the cooperation of the main network in providing the micro-network current faults we would have a higher level of short-circuit fault compared to island format. As can be seen in the following fig. 1 if the relays at island form get regulated properly the observed fault at connected mode would increase and therefore, the coordination of relays would be lost. By the installation of a fault current limiter the provided current fault of the network can be reduced and thereby transfer the protection coordination point towards island mode. This transference can be continued as far as protection coordination conditions are established. Therefore, by the use of fault current limiter we can compensate for the different short-circuit level at functional mode.

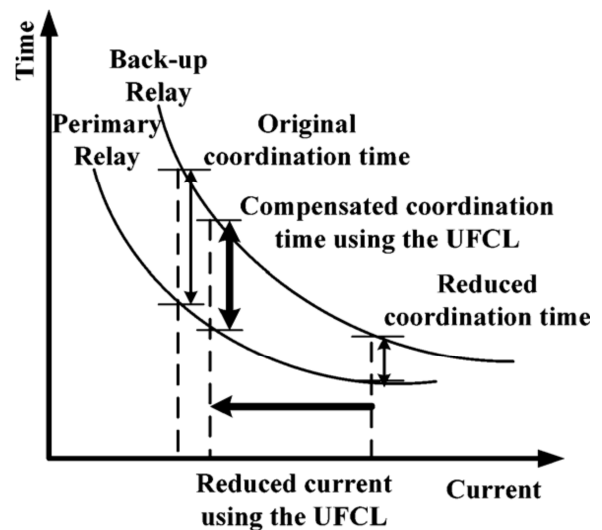

Fig. 1. Regulation relays at island form.

In order to optimize the time of relays we need to regulate the amount of fault current limiter and relays so that the total performance time gets reduced. To this end, additive particles algorithm has been implemented to determine the optimal value of fault current and relay regulations.

Additive particles algorithm is an ultra-explorative optimizing which has imitated the group fly of the birds. In this algorithm each answer of the question is modeled as a particle with n dimension features in the problem

atmosphere. Particles or the answer candidates to the question move under the influence of three factors of current position, best position so far and the best position of the complex to reach the answer to the question. The main relation of particles optimizing algorithm is presented at (4).

$V(t)$ and $X(t)$ respectively speed and position of the particle at frequency t , X_{pbest} the best position of the particle so far X_{gbest} and the best experienced position by the total of the particles. ω inertia index and c_1 and c_2 are the related ratios.

In this article first, the problem solution candidates which consist of fault current limiter data and the relays regulations are generated. Then, by the use of impedance matrix the connected mode fault current to the network by considering the size of the fault current limiter is calculated. Since the fault current limiter connects the network at the connection place it would not affect the island mode short-circuit current level. By having the faults values at two functional modes algorithm calculates the sum of objective function. It needs to be mentioned that lack of observing the coordination conditions is considered as a heavy punishment at the objective function. At the end from the relation (4) answer candidates are updated at each repetition. Fig. 2 displays the implemented flowchart.

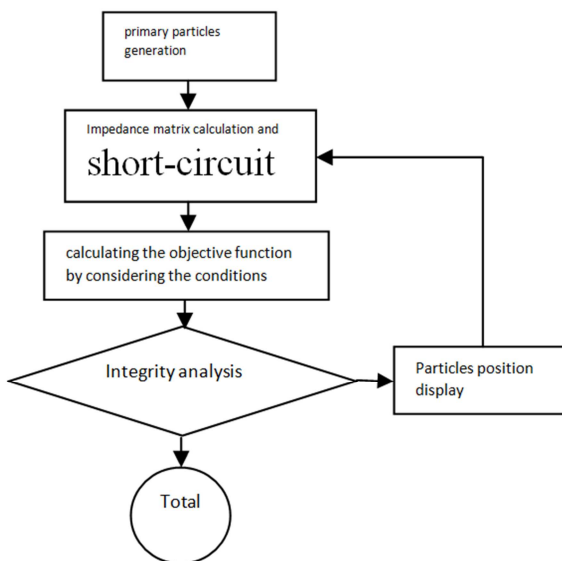

Fig. 2. Implemented flowchart.

4. Simulation Results

The micro network under the study is drawn in Fig. 3. This micro-network consists of three units of synchronous scattered generation which is linked to the main network by bass. The micro-network data has been presented at table 1. Over current relays have been used for the protection of the micro-network.

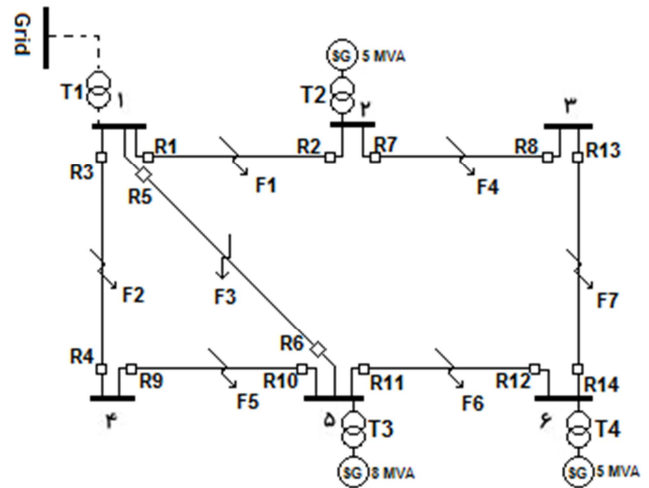

Fig. 3. The micro network under the study.

Table 1. The micro-network data.

12K W20, MVA	Micro-network basis
0.04+0.04j	Impedance line
0.1j	Transient Impedance of generator (on the basis of generator)
0.1j	Impedance of transformer connected to generators' micro networks
200MVA	Short circuit level of main network
0.08j	Impedance of the transformer connected to the micro network to the main network

Table 2 shows relay load currents for two island modes and connected to the network. The assumption is that when in island mode 50% of load depletion would happen. Given the shortness of the fault lines in the middle of the analysis line in the present study three phase faults are considered.

Table 2. Relay load current.

End of the line basbar	Beginning of the line basbar	Load current (per-unit-island mode)	Load current (connected mode to the network-per unit)
1	2	0.056	0.16
1	4	0.0357	0.16
1	5	0.062	0.107
2	3	0.0547	0.126
4	5	0.092	0.055
5	6	0.03	0.109
3	6	0.0626	0.073
Bass 2 unit		0.22	0.18
Bass 5 unit		0.27	0.292
Bass 6 unit		0.168	0.18
Network share			0.65

The sum of the short-circuit currents is calculated by means of impedance matrix method. To this end some virtual bass are use in the middle of the lines. It is supposed that the relay threshold current can be considered at 11-2 times the nominal current. By the use of particles optimizing method for the network under the study optimal protection coordination has been done. The position of the fault limiter

is stable and in the place of connection to the network. After the optimizing fault limiter impedance was obtained at around 0.67 per unit. Table 3 shows the relays optimal regulation sums for the micro network under the study. The protection system total performance time equals 60.9496 seconds. Main relays time performance matrix and support for different faults are shown at table 3.

Table 3. Relays time performance matrix.

Relay No	Regulation ratio	Threshold current
R1	0.2571	0.2064
R2	0.2522	0.176
R3	0.1691	0.176
R4	0.181	0.1984
R5	0.2139	0.1681
R6	0.3089	0.1468
R7	0.2	0.1831
R8	0.2691	0.1671
R9	0.1392	0.1221
R10	0.2854	0.1199
R11	0.2516	0.2028
R12	0.2582	0.123
R13	0.2879	0.1030
R14	0.3433	0.805
R15	0.1896	0.371
R16	0.2286	0.3562
R17	0.2307	0.2393
R18	0.0322	0.7247

Table 4. Relays performance time.

Supporting relays performance time	Main relay performance time	Fault
0.8406, 0.866, 0.8141, 0.8658	0.7017, 0.6258	Island -F1
0.9572, 0.7186, 0.8502	0.6957, 0.566	Island -F2
0.7584, 0.709, 0.974	0.4057, 0.5538	Island -F3
0.5757, 0.7956, 0.8303	0.5567, 0.3995	Island -F4
0.789, 0.8122, 1.3818, 1.3803	0.6387, 0.6215	Island -F5
0.8181, 0.8222, 2.30	0.667, 0.5869	Island -F6
0.842, 0.8184, 0.8084	0.6205, 0.6782	Island -F7
0.8428, 0.7814, 0.7811, 0.8923	0.6311, 0.6205	Connected -F1
0.7024, 0.8221, 0.8644	0.6658, 0.5491	Connected -F2
0.6927, 0.7757, 0.8519, 1.04	0.3774, 0.5383	Connected -F3
0.513, 0.7862, 0.8399, 1.5889	0.5424, 0.362	Connected -F4
0.878, 0.7375, 0.7929, 0.8257, 0.8872	0.6262, 0.5875	Connected -F5
0.7887, 0.822, 0.8108	0.6567, 0.52	Connected -F6
0.7988, 0.7584, 0.8161	0.6079, 0.6488	Connected -F7

Results of the simulation confirm that by the use of fault current limiter we can improve short-circuit level difference in two modes and protect the micro network. Fault current limiter along with optimal regulation as the protect system independent from the micro network performance can be implemented.

5. Conclusion

In the present article fault current limiter was implemented to protect micro network. By the use of this element the short-circuit level difference in two modes of operation would not differ significantly. By the use of particle optimizing algorithm for a suggested micro network over current relays optimal regulation and the fault current limiter impedance was determined. The results show that protection

system is able to protect micro network in both modes of function.

References

- [1] A. Chowdhury and D. Koval, *Power Distribution System Reliability: Practical Methods and Applications*. Hoboken, NJ: Wiley-IEEE, Mar. 2009.
- [2] B. Hussain, S. Sharkh, and S. Hussain, "Impact studies of distributed generation on power quality and protection setup of an existing distribution network," in *Proc. Int. SPEEDAM*, 2010, pp. 1243–1246.
- [3] N. Nimpitiwan, G. T. Heydt, R. Ayyanar, and S. Suryanarayanan, "Fault current contribution from synchronous machine and inverter based distributed generators," *IEEE Trans. Power Del.*, vol. 22, no. 1, pp. 634–641, Jan. 2007.

- [4] P. Bedekar, S. Bhide, and V. Kale, "Optimum coordination of over current relays in distribution system using dual simplex method," in Proc. 2nd ICETET, Dec. 2009, pp. 555–559.
- [5] M. Mansour, S. Mekhamer, and N.-S. El-Kharbawe, "A modified particle swarm optimizer for the coordination of directional overcurrent relays," IEEE Trans. Power Del., vol. 22, no. 3, pp. 1400–1410, Jul. 2007.
- [6] P. Bedekar, S. Bhide, and V. Kale, "Optimum coordination of overcurrent relays in distribution system using genetic algorithm," in Proc. ICPS, 2009, pp. 1–6.
- [7] P. P. Bedekar and S. R. Bhide, "Optimum coordination of directional overcurrent relays using the hybrid GA-NLP approach," IEEE Trans. Power Del., vol. 26, no. 1, pp. 109–119, Jan. 2011.
- [8] C. So and K. Li, "Time coordination method for power system protection by evolutionary algorithm," IEEE Trans. Ind. Appl., vol. 36, no. 5, pp. 1235–1240, Sep./Oct. 2000.
- [9] M. Barzegari, S. Bathaee, and M. Alizadeh, "Optimal coordination of directional overcurrent relays using harmony search algorithm," in Proc. 9th Int. Conf. IEEEIC, May 2010, pp. 321–324.
- [10] H. Sharifian, H. Askarian Abyaneh, S. Salman, R. Mohammadi, and F. Razavi, "Determination of the minimum break point set using expert system and genetic algorithm," IEEE Trans. Power Del., vol. 25, no. 3, pp. 1284–1295, Jul. 2010.
- [11] Q. Yue, F. Lu, W. Yu, and J. Wang, "A novel algorithm to determine minimum break point set for optimum cooperation of directional protection relays in multiloop networks," IEEE Trans. Power Del., vol. 21, no. 3, pp. 1114–1119, Jul. 2006.
- [12] A. Noghabi, J. Sadeh, and H. Mashhadi, "Considering different network topologies in optimal overcurrent relay coordination using a hybrid GA," IEEE Trans. Power Del., vol. 24, no. 4, pp. 1857–1863, Oct. 2009.
- [13] A. Noghabi, H. Mashhadi, and J. Sadeh, "Optimal coordination of directional overcurrent relays considering different network topologies using interval linear programming," IEEE Trans. Power Del., vol. 25, no. 3, pp. 1348–1354, Jul. 2010.
- [14] P. Barker and R. De Mello, "Determining the impact of distributed generation on power systems. I. Radial distribution systems," in Proc. IEEE Power Eng. Soc. Summer Meeting, 2000, pp. 1645–1656.
- [15] A. Girgis and S. Brahma, "Effect of distributed generation on protective device coordination in distribution system," in Proc. LESCOPE, 2001, pp. 115–119.
- [16] W. El-Khattam and T. Sidhu, "Restoration of directional overcurrent relay coordination in distributed generation systems utilizing fault current limiter," IEEE Trans. Power Del., vol. 23, no. 2, pp. 576–585, Apr. 2008.